

## Note

**Title & Document Type:** 10762A Comparator for 5501A  
**Manual Part Number:** 10762-90007  
**Serial Prefixes:** 1852A  
**Revision Date:** Oct 1978

### HP References in this Manual

This manual may contain references to HP or Hewlett-Packard. Please note that Hewlett-Packard's former test and measurement, semiconductor products and chemical analysis businesses are now part of Agilent Technologies.

### Changes to this Manual

No changes have been made to this manual. All pages are scanned at 300 DPI or greater.

### About this Manual

This manual is reproduced from scans of an original document and images OCR'd with Adobe Acrobat. OCR errors may exist and as such the user of this document should take care and use common sense when referencing this documentation.

### Copyright Notice

This documentation is © Copyright 1978 Hewlett Packard and © Copyright 2010, Jack Hudler, [hpdocs@hudler.org](mailto:hpdocs@hudler.org).

Permission to use and redistribute this documentation for non-commercial and internal corporate purposes is hereby granted, free of charge. Any redistribution of this documentation or its derivatives must include this copyright notice.

You **may not** sell this documentation or its derivations without written consent. You may modify this documentation as necessary, but you may not sell derivative works based on it. You may include this documentation with the equipment/hardware on which it is used for the purposes of selling the equipment/hardware. If you advertise that a copy of this documentation is included in the sale, you must state that is for "Free".

Meaning if you want to gratuitously toss in a copy of the manual on an eBay sale, it's ok with me as long as you state it's for free. No you can't sell a digital archive of manuals and say it includes a free copy of this documentation. You must give it away with equipment.

I think you get the spirit of the copyright; it takes a lot of hours to scan and replicate a manual. I just want this used in the spirit in which is it given.

Agilent if you have questions or wish to include this in your archive, please email me.

# OPERATING AND SERVICE MANUAL

## **COMPARATOR** (PART of 5501A LASER TRANSDUCER SYSTEM)

### **10762A**

#### **SERIAL PREFIX**

This manual applies directly to Hewlett-Packard Model 10762A Comparators with serial prefix 1852A and below.

For serial prefixes after 1852A, a "Manual Change Sheet" is included with this manual.

**Printed: OCTOBER 1978**

Copyright                      HEWLETT-PACKARD COMPANY                      1977  
5301 STEVENS CREEK BLVD., SANTA CLARA, CALIFORNIA, 95050

**Manual Part No. 10762-90007**  
**Microfiche Part No. 10762-90008**

**Printed in U.S.A.**

## **CERTIFICATION**

*Hewlett-Packard Company certifies that this instrument met its published specifications at the time of shipment from the factory. Hewlett-Packard Company further certifies that its calibration measurements are traceable to the United States National Bureau of Standards, to the extent allowed by the Bureau's calibration facility, and to the calibration facilities of other International Standards Organization members.*

## **WARRANTY AND ASSISTANCE**

This Hewlett-Packard product is warranted against defects in materials and workmanship for a period of one year from the date of shipment. Hewlett-Packard will, at its option, repair or replace products which prove to be defective during the warranty period provided they are returned to Hewlett-Packard, and provided the preventive maintenance procedures in this manual are followed. Repairs necessitated by misuse of the product are not covered by this warranty. NO OTHER WARRANTIES ARE EXPRESSED OR IMPLIED, INCLUDING, BUT NOT LIMITED TO, THE IMPLIED WARRANTIES OF MERCHANTABILITY AND FITNESS FOR A PARTICULAR PURPOSE. HEWLETT-PACKARD IS NOT LIABLE FOR CONSEQUENTIAL DAMAGES.

Service contracts or customer assistance agreements are available for Hewlett-Packard products.

For any assistance, contact your nearest Hewlett-Packard Sales and Service Office. Addresses are provided at the back of this manual.

## SECTION I GENERAL INFORMATION

### 1-1. SCOPE OF THIS MANUAL

1-2. This manual provides installation, operation, and service information for the HP Model 10762A Comparator. The 10762A (see Figure 1-1) is a printed-circuit board optional unit for the HP Model 5501A Laser Transducer System. The 10762A plugs into the HP Model 10740A Coupler, a multiple-board module which provides the majority of interconnections within the 5501A system.

#### NOTE

Programming information for the 10762A is contained in the 5501A System Manual.

Figure 1-1. 10762A Comparator

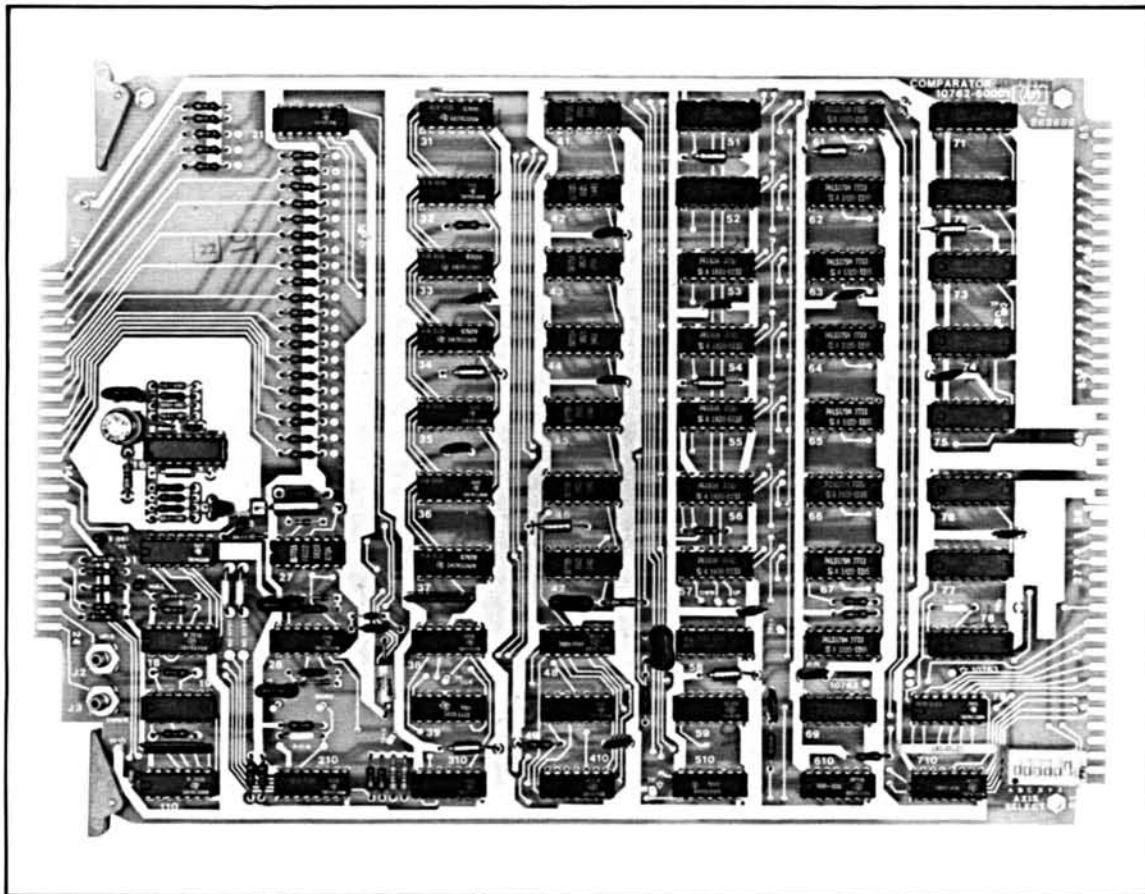

### **1-3. HP 10762A COMPARATOR DESCRIPTION**

1-4. The HP 10762A Comparator is used in a closed-loop feedback-controlled position (distance) measuring system. Such a measuring system requires the ability to control the position of some device. This includes measuring the device position and generating a position correction signal to move the device to the desired position. The 10762A can compare a measured movement signal with a desired position (destination) signal and generate a position correction (digital difference) signal.

### **1-5. EQUIPMENT SUPPLIED**

1-6. The 10762A consists of a 10762-60001 printed circuit board, a 5060-8339 48-pin connector kit, and this manual.

### **1-7. INFORMATION IN OTHER MANUALS**

1-8. The 10762A is used with the HP Model 10764A Fast Pulse Converter, 10746A Binary Interface, and other units in the 10740A Coupler. For a complete understanding of the 10762A in a system, the user should be familiar with these manuals as well as the 5501A Laser Transducer System Manual.

### **1-9. MANUAL MICROFICHE**

1-10. On the title page of this manual, below the manual part number is a "microfiche" part number. This number may be used to order 4 x 6-inch microfilm transparencies of the manual. The microfiche package should include all pertinent Service Notes, but Manual Change sheets must be requested separately (see next paragraph).

### **1-11. PRINTED-CIRCUIT BOARD IDENTIFICATION AND MANUAL CHANGES**

1-12. Each 10762A printed-circuit board has a four-digit series identification number (e.g., 1512). The series number identifies a group of identical printed-circuit boards. If the series number on your board is a higher number than the series number on the title page of this manual, a change sheet should be included that describes the differences between series numbers. If the change sheet is missing, request one from the nearest Hewlett-Packard Sales and Service Office (see the HP offices listing at the back of this manual). If your board has a series number lower than that shown on the title page, refer to the Manual Changes section, page 7-1, for differences in the documentation.

### **1-13. SAFETY CONSIDERATIONS**

1-14. This manual contains information, cautions, and warnings which must be followed by the user to ensure safe operation and to retain the instrument in good operating condition.

### **1-15. HP 10762A SPECIFICATIONS**

1-16. Specifications of the 10762A are given in Table 1-1.

Table 1-1. HP Model 10762A Comparator Specifications

**Input Signal:** Up/Down or Phase-quadrature (A-Quad-B) Pulses. Minimum 50 nanosecond pulse width, maximum 10 MHz.

**Measurement Accuracy:**  $\pm 0.5$  PPM  $\pm 1$  count in conjunction with 5501A Laser Transducer and 10764A Fast Pulse Converter.  $\pm 2$  counts if hysteresis circuit selected.

**Destination and Tolerance:** Input from system controller via 10746A Binary Interface. The digital difference output is automatically forced to null or zero difference when the destination and tolerance are loaded.

**Format:** 32-bit word. Four tolerance bits ( $\pm 15$  counts) and 28 position bits can be transferred from system controller as either two 16-bit words or four 8-bit bytes.

**Input Rate:** Nine individual operations at typically 1 microsecond each are required to transfer two 32-bit words from the system controller to two 10762A Comparators using the two 16-bit word format in conjunction with the 10746A Binary Interface.

**Digital Difference Output:** Available at card edge connector.

**Format:** 28-bit TTL level. Sign-magnitude: binary negative-true representation. Twenty-four most significant bits can be wired-OR'ed for variable linearity.

**Response:** One microsecond typical for constant velocity; 2 microseconds typical under acceleration conditions; relative to motion detected by the interferometer.

**Null Output:** Occurs when the 28-bit counter agrees with the 28-bit destination within the four tolerance bits ( $\pm 15$  counts). This signal is available both externally at the card edge connector and to the system controller via the 10746A Binary Interface.

**External Null Output:** TTL level change, active low.

**Responses:** 1.1 microsecond typical for constant velocity; 2.1 microseconds typical under acceleration conditions; relative to motion detected by the interferometer.

**System Null:** Available to system controller (via 10746A card) when all 10762A Comparators are at a null condition. TTL level change, active high.

**Zero Speed Output:** Occurs when no counts have entered the Up/Down Counter within 17 msec (variable from 1 to 100 msec); TTL level change, active high.

**Reset:** Initializes Up/Down Counter at 160 counts. Can be initiated either externally or by the system controller via the 10746A Binary Interface. Reset also activates a Forced Null condition on the Digital Difference Output.

**External:** TTL level change, active low. Reset conditions will be maintained until returned to the high state.

**System Controller:** The counter on a specific 10762A Comparator can be reset or all 10762A Comparator counters in the system can be reset simultaneously under program control.

**Sample:** Places Up/Down Counter contents in output latches for transfer to system controller. Also releases the Forced Null on the Digital Difference Output after loading destination and tolerance. Can be initiated either externally or by the system controller via the 10746A Binary Interface.

**External:** TTL level change; active low. Minimum 40 nanosecond pulse width.

**System Controller:** The counter on a specific 10762A Comparator can be sampled or all 10762A Comparator counters can be sampled simultaneously under program control.

**External Forced Null:** TTL level change, active low; forces the Digital Difference Output to zero difference regardless of the actual difference and the Null output to a low state. The external Forced Null will be maintained until returned to the high state.

**Forced Zero Speed:** TTL level change, active low; forces the Zero Speed output to a high state regardless of actual conditions. The forced zero speed condition will be maintained for the duration of the zero speed time constant after being returned to the high state.

Table 1-1. HP Model 10762A Comparator Specifications (continued)

**Counter Output:** The contents of the 28-bit Counter of the 10762A Comparator along with 4 status bits from both the 10762A Comparator and the 10764A Fast Pulse Converter are available for transfer to the system controller via the 10746A Binary Interface.

**Format:** 32-bit word; 28-bit position word with 4 status bits which allow detecting measurement or reference signal errors, counter overflow, system null and decimal point. Can be transferred to system controller as two 16-bit words or four 8-bit bytes.

**Output Rate:** Nine individual operations at typically 1 microsecond each are required to transfer two 32-bit words to the system controller from two 10762A Comparators using the two 16-bit word format in conjunction with the 10746A Binary Interface. (Refer to Table 4-7 in Systems Manual.)

**Atmospheric and Material Temperature Compensation Input:** Manual Compensation factor input standard (tables supplied); Automatic Compensator Option (Option 402).

## SECTION II INSTALLATION

### 2-1. INTRODUCTION

2-2. This section describes procedures for unpacking, setting up, and installing the 10762A Comparator.

### 2-3. UNPACKING AND INSPECTION

2-4. Inspect the 10762A for visible damage. If the unit is damaged, notify the carrier and the nearest Hewlett-Packard Sales and Service Office immediately (offices are listed at the back of this manual). Keep the shipping carton and packing material for the carrier's inspection. The HP Sales and Service Office will arrange for repair or at HP's option replacement of damaged items without waiting for the claim against the carrier to be settled.

### 2-5. PREPARATION FOR USE

2-6. The following paragraphs provide information necessary to prepare the 10762A for use. Included are power requirements, operating environment, installation, interconnecting cables, and warranty claims.

### 2-7. POWER REQUIREMENTS

2-8. The 10762A receives operating power from the 10740A Coupler. Power required is +5 volts at 1.8 amperes.

### 2-9. OPERATING AND NON-OPERATING ENVIRONMENT

2-10. The 10762A can be used in the following environments:

#### OPERATION

Temperature: 32°F to 130°F (0°C to 55°C)  
Relative Humidity: 0% to 95%

#### STORAGE

Temperature: -40°F to +167°F (-40°C to +75°C)  
Relative Humidity: 0% to 95%

### 2-11. INSTALLATION

#### CAUTION

**Switch OFF power to 10740A Coupler before installing or removing a circuit board.**

2-12. Refer to Figure 2-1, 10762A Installation in 10740A Coupler. Before plugging in the 10762A read the remainder of this section, in particular the paragraphs on jumper and switch settings. Coordinate this information with the paragraphs on Comparator-Based System Installation in Section V of the 5501A Laser Transducer System Manual.



Figure 2-1. Installation

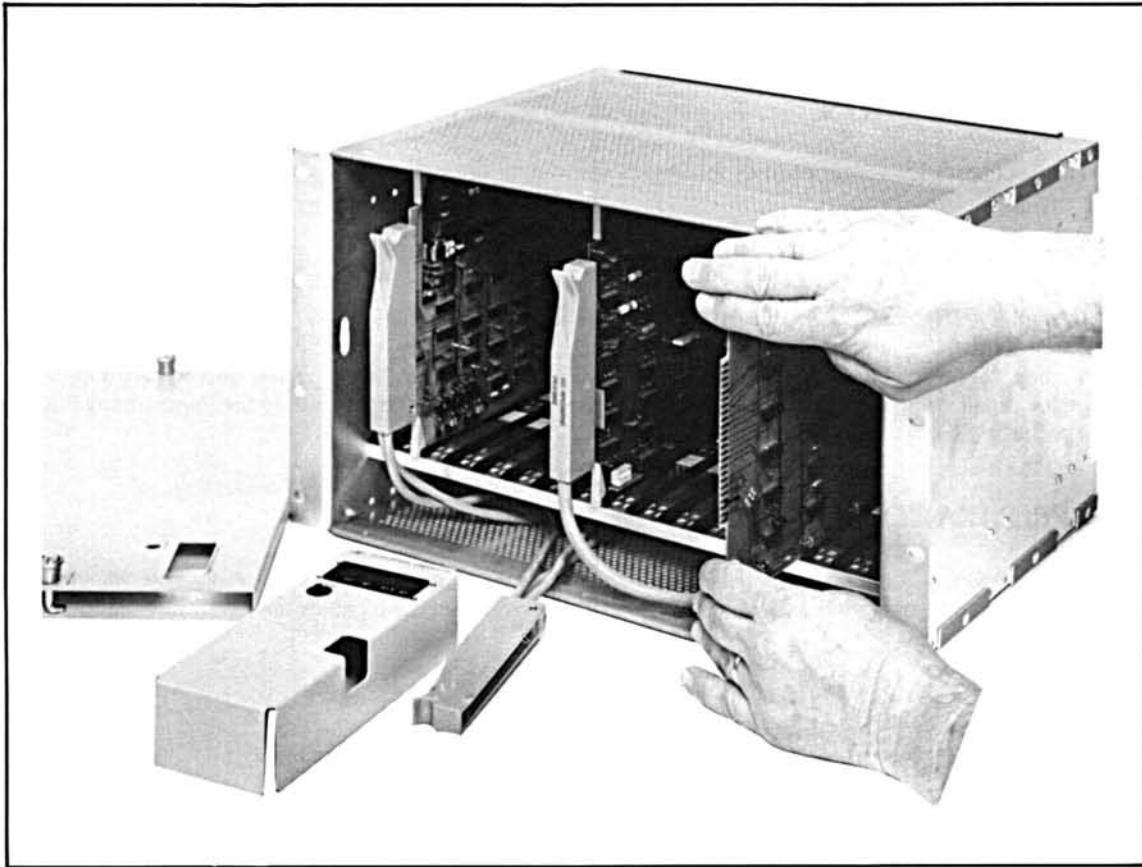

### 2-13. CONNECTORS

2-14. The dual 43-pin (86) connector edge mates with rear coupler connector number 1251-3755. The dual 24-pin (48) connector edge mates with connector kit number 5060-8339. The 86 pins of the rear connector (P1) are connected in parallel to the coupler bus or backplane. The signals on these lines are shown in Table 2-1 (following page). The signals on the front edge connector (J1) are listed in Table 2-2.

### 2-15. WARRANTY CLAIMS

2-16. Contact the nearest Hewlett-Packard Sales and Service Office (see manual back cover) for information relative to warranty claims.

### 2-17. PACKAGING FOR RESHIPMENT

2-18. The same containers and materials used in factory packaging can be obtained through the Hewlett-Packard Sales and Service Offices listed at the back of this manual.

2-19. If the 10762A is being returned to Hewlett-Packard for service, attach a tag indicating the type of service required, return address, model number and full serial number. Mark the container FRAGILE to assure careful handling.

2-20. In all correspondence with Hewlett-Packard always reference the full model number and serial number of the board.

Table 2-1. 10740A Coupler Bus Lines (Backplane)

FUNCTION	PINS	NAMES	PINS	NAMES
POWER	{	1 +15 VOLTS	{	2 +15 VOLTS
		3 -15 VOLTS		4 -15 VOLTS
		5 ±15 RETURN		6 ±15 RETURN
INSTRUCTIONS	{	7 SPARE	{	8 SPARE
		9 CARD ADDRESS-A		10 CARD ADDRESS-B
		11 CARD ADDRESS-C		12 CARD ADDRESS-D
		13 CARD CMD-A		14 CARD CMD-B
		15 CARD CMD-C		16 CARD CMD-D
STATUS	{	17 DATA VALID	{	18 DATA VALID
		19 INSTRUCTION VALID		20 INSTRUCTION VALID
		21 OPERATION COMPLETE		22 OPERATION COMPLETE
SYSTEM COMMANDS	{	23 SAMPLE	{	24 PWR-UP/SYSTEM RESET
ERRORS	{	25 REF ERROR-BIT	{	26 MEAS ERROR-BIT
		27 V.O.L. ERROR-BIT		28 OVFL-BIT
DECIMAL POINT (TOLERANCE BITS)	{	29 D.P.-BIT-1	{	30 D.P.-BIT-0
		31 D.P.-BIT-3		32 D.P.-BIT-2
MODE-STATUS	{	33 λ-MODE BIT	{	34 SYSTEM NULLED
		35 SPARE		36 SPARE
		Key →		Key →
POWER	{	37 +5V RETURN	{	38 +5V RETURN
		39 +5V RETURN		40 +5V RETURN
		41 +5 VOLTS		42 +5 VOLTS
		43 +5 VOLTS		44 +5 VOLTS
		45 +5 VOLTS		46 +5 VOLTS
		47 +5V RETURN		48 +5V RETURN
		49 +5V RETURN		50 +5V RETURN
		51 SPARE		52 SPARE
DATA	{	53 DATA BIT 1	{	54 DATA BIT 0
		55 DATA BIT 3		56 DATA BIT 2
		57 DATA BIT 5		58 DATA BIT 4
		59 DATA BIT 7		60 DATA BIT 6
		61 DATA BIT 9		62 DATA BIT 8
		63 DATA BIT 11		64 DATA BIT 10
		65 DATA BIT 13		66 DATA BIT 12
		67 DATA BIT 15		68 DATA BIT 14
		69 DATA BIT 17		70 DATA BIT 16
		71 DATA BIT 19		72 DATA BIT 18
		73 DATA BIT 21		74 DATA BIT 20
		75 DATA BIT 23		76 DATA BIT 22
77 DATA BIT 25	78 DATA BIT 24			
79 DATA BIT 27	80 DATA BIT 26			
		81 }		82 }
		83 } MAKE NO CONNECTION		84 } MAKE NO CONNECTION
		85 }		86 }

Table 2-2. 10762A Comparator J1 Front Connector Pins

		J1	10762A Front Edge Connector
<p>DIFFERENCE OUTPUT BITS: Sign bit plus 28 data bits. TTL-level, binary negative true (active low).</p> <p>For output to digital-to-analog converter and device servomotor.</p>	D27 — <b>A</b>		1 — SIGN
	D25 — <b>B</b>		2 — D26
	D23 — <b>C</b>		3 — D24
	D21 — <b>D</b>		4 — D22
	D19 — <b>E</b>		5 — D20
	D17 — <b>F</b>		6 — D18
	D15 — <b>H</b>		7 — D16
	D13 — <b>J</b>		8 — D14
	D11 — <b>K</b>		9 — D12
	D9 — <b>L</b>		10 — D10
	D7 — <b>M</b>		11 — D8
	D5 — <b>N</b>		12 — D6
	D3 — <b>P</b>		13 — D4
	D1 — <b>R</b>		14 — D2
	D0 — <b>S</b>		
+5V input		<b>T</b>	16
EXTERNAL RESET: input from external device. TTL-level change, active low, min. 50 ns pulse.			19 (Component side)
FORCED ZERO SPEED: input from external device. TTL-level change, active low.		<b>W</b>	20
EXTERNAL SAMPLE: input from external device. TTL-level change, active low, min. 40 ns pulse.			21
NULL: Output to external device. TTL-level change, active low.		<b>X</b>	22
FORCED NULL: input pulse from external device. TTL-level change, active low.			23
ZERO SPEED: Output to external device. TTL-level change, active high.		<b>Y</b>	24
Common		<b>Z</b>	(J2)
UP/A: up or A-quad pulse from 10764A			(J3)
$\overline{\text{UP/A}}$ : complement of UP/A pulse		<b>AA</b>	
DWN/B: down or B-quad pulse from 10764A			
$\overline{\text{DWN/B}}$ : complement of DWN/B pulse		<b>BB</b>	
			0

## 2-21. ADDRESSES AND COMMANDS (INSTRUCTIONS)

2-22. The 10762A responds to coded addresses and commands from the 10740A Coupler bus. The 10762A address is selectable by a switch (see paragraph 2-28). Table 2-3 lists the specific instructions and responses for the 10762A. Coordinate this table with the programming information in Section IV of the Systems Manual.

Table 2-3. 10762A Comparator Instructions

The Backplane (Coupler Bus) address is selectable. Addresses are mutually exclusive and may be X, Y, Z, A, B, or C.			
<b>ADDRESSED INSTRUCTIONS</b>			
<b>INSTRUCTION COMMAND</b>	<b>ADDRESS*</b>		<b>RESPONSE</b>
0	X	RESET* *	Preset up/down counter register to 160 counts, force digital difference output to null, clear OVFL-BUFFER.
1	X	SAMPLE* *	Release forced null. Load contents of up/down counter into bus output latches as soon as there is a window wide enough to insure that a count is not propagating through the count chain.
2	X	OUTPUT	Output contents of bus output latches to backplane data bus, output mode ( $\lambda/4$ or $\lambda/8$ ), output decimal point code, output contents of OVFL-ERROR buffer.
3	X	LOAD DESTINATION	Load destination register with 28-bit number and tolerance register with 4-bit number from 10740A backplane.
4	X	TEST	Disable UP/A and DWN/B inputs and count down at 10 MHz. (Terminates with a sample instruction, or an underflow in count register).
7	X	TEST	Disable UP/A and DWN/B inputs and count up at 10 MHz. (Terminates with a sample instruction or an overflow in count register.)
10740A Coupler Bus Reset		Same as OX	
10740A Coupler Bus Sample		Same as 1X	
<b>NOTE</b>			
**"X" is used as an example of the address in this chart. To make instruction apply to another comparator simply replace "X" with that card's address (Y or Z or A or B or C).			
* *Can also be initiated externally on J1.			

## 2-23. JUMPER AND SWITCH SETTINGS

2-24. The 10762A contains a selectable address switch and a number of jumper wires and removable resistors. The 10762A is shipped from the factory with all jumper wires in predetermined positions and soldered in place. However, the jumper wires can be changed to accommodate requirements of a particular system.

2-25. Figure 2-2 shows the locations of all the selectable position jumper wires, the address switch, and test points.

### CAUTION

**The jumper wires should only be changed by qualified service personnel.**

### NOTE

All factory-installed jumper wires have a small piece of white plastic insulation on them that resembles the body of a small electronic component. The wires are straight through the insulation, and they only have the slight resistance, inductance, and capacitance of a normal short piece of wire.

## 2-26. CHANGING JUMPER WIRES

2-27. If it is desirable or necessary to change the position of a jumper wire, use the following lettered instruction steps:

### CAUTION

**Use a small soldering iron (35 watts or less) to heat the jumper wire connections. Larger wattage soldering irons may damage the printed circuit-board. The jumper wire holes in the printed-circuit board have metal plated-through walls to ensure good electrical contact. Apply heat sparingly and work carefully to avoid damaging the metal plated conductors and the insulating board.**

- a. Heat the jumper wire connections with a soldering iron and remove the solder with a solder removing tool. (Good commercial solder "sucking" tools are recommended.)
- b. Remove the loose jumper wire with pliers. It may be necessary to heat the connections with the soldering iron while pulling the wire with pliers.
- c. Clean the excess solder from the wire ends with the soldering iron.

### NOTE

Use only high quality electronic grade solder.

- d. Put the jumper wire ends into the selected holes, and solder the connections carefully.
- e. Clean the connection area on the board with a good commercial electronic solder flux solvent.
- f. End of procedure.



## **2-28. ADDRESS SWITCH "A, B, C, X, Y, Z" (S1)**

2-29. The 10762A operates in the Laser Transducer system through the 10740A Coupler backplane. A system controller, such as a calculator or computer, can be programmed to control one or more 10762A Comparators. Each 10762A in one system must have a separate "address" to receive instructions from the controller. Each 10762A can be set to respond to one of six addresses by placing all switches toward the dot on component S1 (reference Figure 8-2), then moving the switch corresponding to the address desired (A, B, C, X, Y, or Z) away from the dot.

2-30. There is no required specific address for any axis of a system, but for convenience the address "X" is typically assigned to the 10762A for the "X" axis of a system, the "Y" address for the "Y" axis, and the "Z" address for the "Z" axis.

2-31. Select one of the letters A, B, C, X, Y or Z for the 10762A address, and then move the individual switch in line with the selected letter. All other switches must be in the opposite (dot) position.

### **NOTE**

Only one of the six "addresses" may be used on one 10762A Comparator at one time.

## **2-32. PULSE OR A-Q-B (A-QUADRATURE-B OR UP-DOWN PULSE) JUMPER WIRES**

2-33. The HP 10762A can accept two kinds of electrical displacement information. Either "Up/Down" pulses representing displacement (movement) or A-quadrature-B displacement signals are usable by the 10762A. The PULSE or A-Q-B jumper wire position is selected depending upon which type of displacement signal will be applied to the 10762A. Figure 2-2 shows the location of the PULSE/A-Q-B jumper wire positions on the board. A jumper wire is shown in the PULSE position.

### **NOTE**

When a jumper is properly installed either the PULSE legend (for Pulse mode) or A-Q-B legend (for A-quadrature-B mode) is obscured.

## **2-34. Pulse Input Coaxial Connectors**

2-35. The up/down or A-quad-B input pulses to the 10762A should be applied through coaxial cable connectors from a 10764A card to the 10762A front coax connectors J2 and J3. Parallel connections are provided on the J1 connector for non-standard configurations.

## **2-36 HYSTERESIS/NO HYSTERESIS JUMPER WIRES**

2-37. A pair of jumper wires must be soldered in one of two matching positions depending on whether the hysteresis option is selected. One pair of positions is labelled HYST (indicating hysteresis) the other pair of positions is labelled NO HYST (indicating non-hysteresis mode).

### **NOTE**

When the two hysteresis jumpers are properly installed for the no hysteresis mode, the NO HYST legends are obscured. When the two hysteresis jumpers are properly installed for the hysteresis mode, the HYST legends are obscured.

2-38. In a movable mechanical system with a closed feedback loop the system may tend to oscillate near the null point. Alternate direction signals at the null can be undesirable. If the hysteresis mode is selected the 10762A will ignore the first single opposite direction counter pulse as the null is passed. If single alternating direction counter pulses are received by the 10762A in hysteresis (HYST) mode, no difference output signal will be produced. In the 10762A no-hysteresis (NO HYST) mode every counter pulse received, even as a null is passed, will produce a difference output signal from the 10762A.

## 2-39. $\lambda/4$ , $\lambda/8$ JUMPER WIRES

2-40. The alternate jumper wire positions labelled  $\lambda/4$  and  $\lambda/8$  allow the 10762A to be set to agree with other units in a system. The jumper is normally set in the  $\lambda/4$  position when the 10762A is shipped from the factory.

### NOTE

When the jumper is properly installed the selected legend " $\lambda/4$ " or " $\lambda/8$ " is obscured.

### NOTE

When the 10706A Plane Mirror Interferometer is used in the Laser system optics, system configurations may require this jumper to be set to " $\lambda/8$ " to signify the counter contents represent  $\frac{1}{8}$  wavelength units.

## 2-41. DIGITAL DIFFERENCE OUTPUT-VARIABLE LINEARITY

2-42. The 10762A digital difference output can be selectively jumpered to alter the response speed of the system being controlled. Each of the 24 most-significant bits of the difference output can be wire-OR'ed with the next less-significant bit. The effect of this is to maintain the same output voltage/speed over a selected range toward the destination even though the output of the 28-bit subtractor is linearly decreasing. The wired-OR'ing process for each output bit requires removal of a resistor and addition of a jumper wire directly below.

2-43. See Figure 2-2 for location of the removable resistors and replacement wires for the wired-OR condition. See Figure 2-3 for an example of selective jumpering that maintains maximum speed over most of the system travel, then decreases gradually toward null.



Figure 2-3. Example of Jumpering Difference Output Bits for Variable Linearity

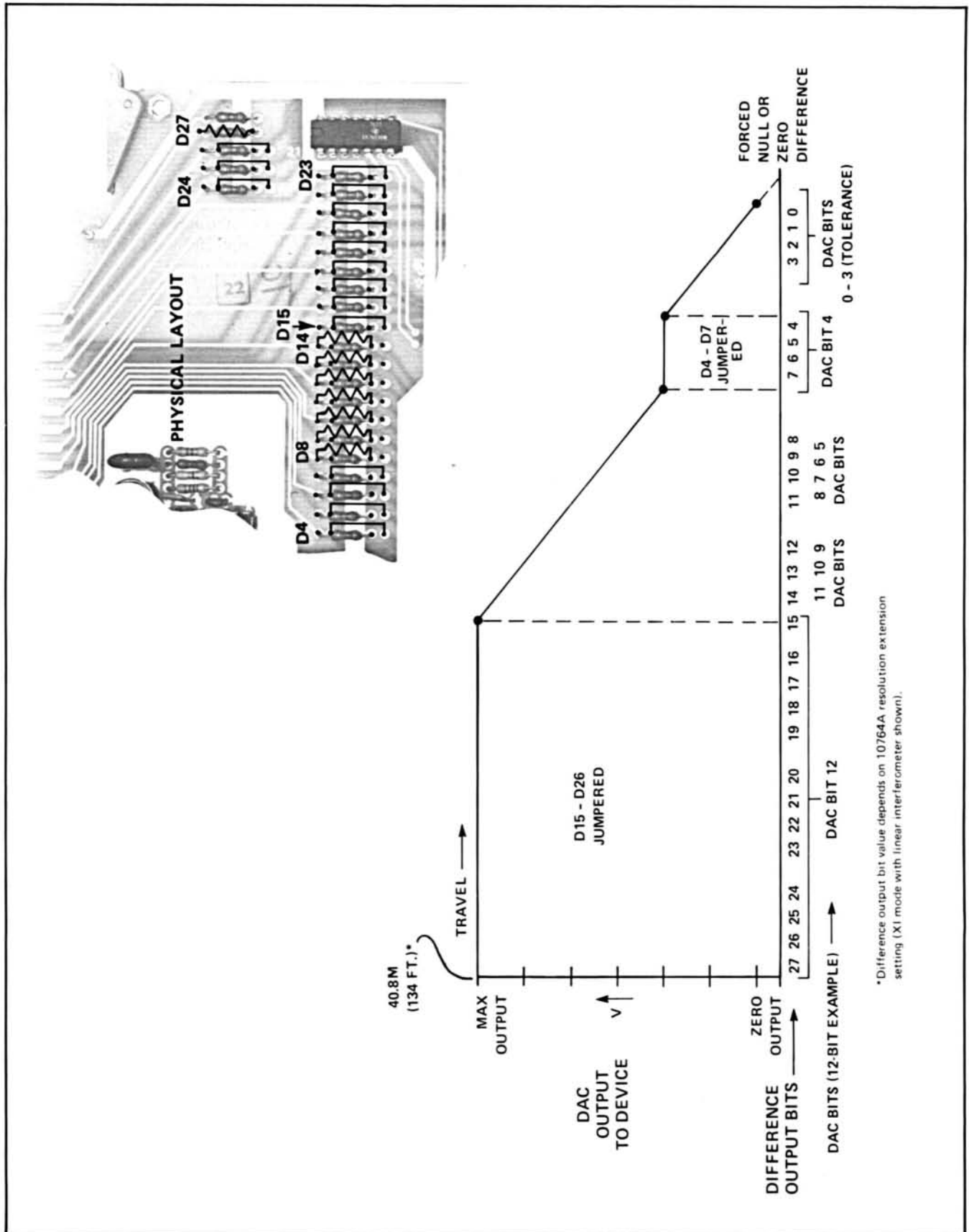

## SECTION III OPERATION

### 3-1. OPERATOR REQUIREMENTS

3-2. The 10762A does not have any operating controls, but it does have three light-emitting diodes (LED's) to indicate certain conditions. Table 3-1 lists the LED indicators (DS), names, and functions.

*Table 3-1. LED Indicator Functions*

DS	NAME	FUNCTION (On Indicates)
1	+5	+5 volts and return applied to card.
2	NULL	Destination and location of system are equal (null exists) or a forced null exists.
3	SPD = 0	Zero speed, or system not moving

## SECTION IV THEORY OF OPERATION

### 4-1. INTRODUCTION

4-2. The 10762A is a primary component of the Comparator Based (Closed Loop) System as described in the 5501A Systems Manual under the general category of Computer Interface Electronics. This section provides a general introduction to system level usage followed by a description of detailed theory at the block level.

### 4-3. SYSTEM PURPOSE AND CONFIGURATION

4-4. As shown in Figure 4-1 below, the 10762A operates with other units to form a high-speed closed-loop control system. Typically, a system controller sends the system a digital number representing the destination of the device under control. The system then closes the loop by continually measuring the device distance while subtracting the destination number and causing the device to move toward its destination.

Figure 4-1. Typical Components For Closed Loop Control Systems

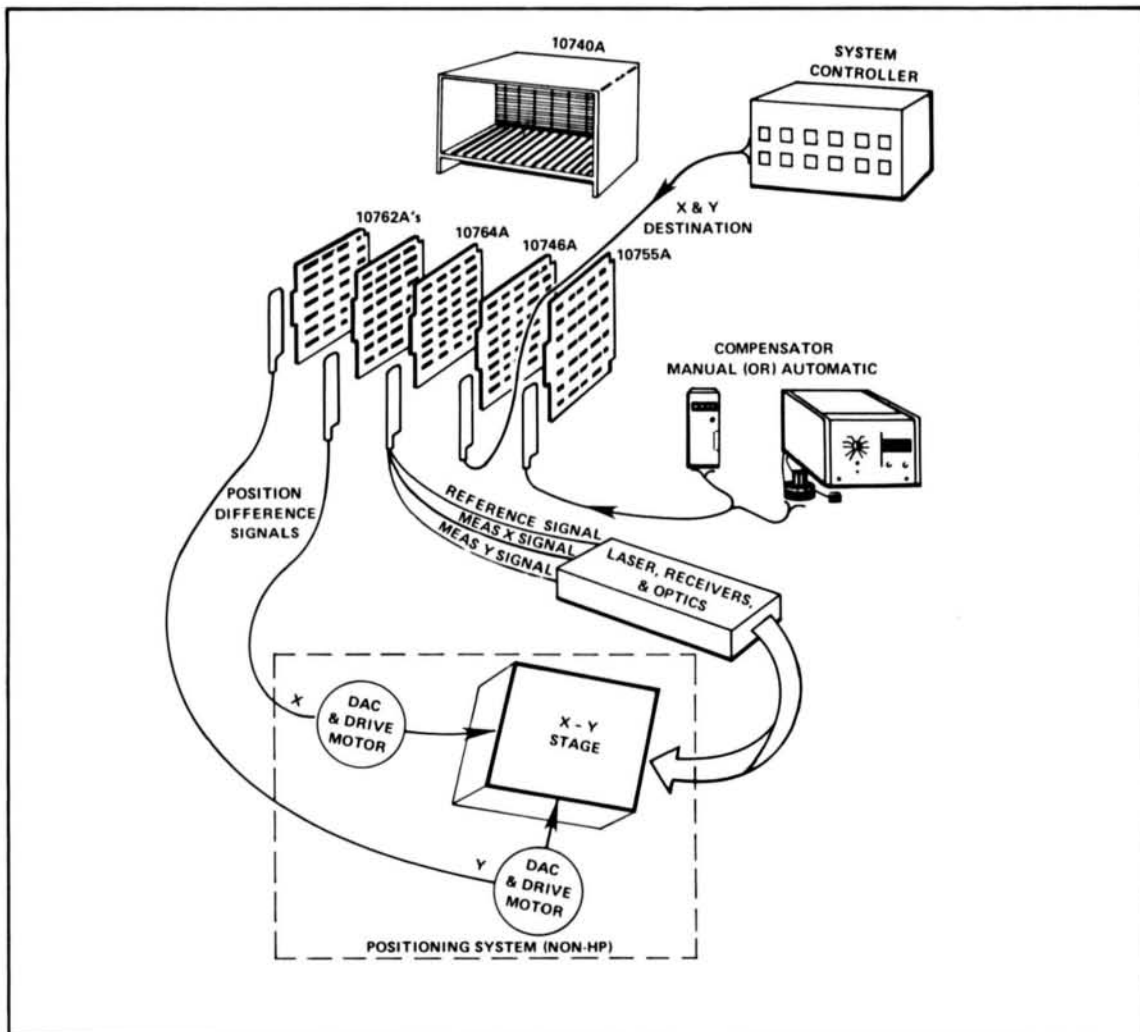

4-5. One 10762A is used for each axis required by the controlled device. One 10764A Fast Pulse Converter is required for each pair of 10762A's to provide up/down pulses derived from the laser optics. A 10746A Binary Interface is required to interface with the system controller, and a 10755A Compensation Interface is required if manual or automatic environmental compensation is used.

4-6. Refer to Section 3 of the 5501 Systems Manual for further system description.

## **4-7. THEORY OF OPERATION**

4-8. Correlate the following paragraphs with the corresponding blocks of Figure 4-2.

### **4-9. UP/DOWN OR A-QUAD-B PULSE INPUT**

4-10. The primary signal input to the 10762A is either up/down pulses from the 10764A Fast Pulse Converter or optionally A-quadrature-B signals from some other source. The up/down or A-quad-B pulse input circuit receives the input signals, buffers them, and applies them to the up/down counter. The optional hysteresis circuit can be connected between the up/down pulse input and the counter.

### **4-11. OPTIONAL HYSTERESIS**

4-12. The optional hysteresis circuit allows the comparator to ignore the first pulse after any change of direction. This prevents a jittering effect that is possible when the device under control is actually stopped. High system sensitivity can cause alternate up and down pulses when the device under control is stopped. If hysteresis is selected (see Section II), the first pulse after a change in direction is ignored by the comparator.

### **4-13. ZERO SPEED**

4-14 The zero speed circuit monitors whether the up/down (or A-quad-B) pulses, indicating movement of the controlled device, are being received by the comparator. If no pulses are received for a certain time, the zero speed signal line is set true. The factory time setting for a zero speed true signal is about 20 milliseconds. It is possible to change this time if desired. A qualified electronics technician can select the time by changing the value of the resistor and capacitor connected to pin 11 of U27. The zero speed circuit monitors the up-down pulses after the hysteresis circuit.

### **4-15. 28-BIT UP/DOWN COUNTER**

4-16. The 28-bit up/down counter accepts the pulse output of the up/down pulse input-hysteresis circuit and counts these pulses (representing device movement) for output to the 28-bit subtractor and through the bus output latches to the 10740A Coupler bus.

### **4-17. BUS OUTPUT LATCHES**

4-18. One output of the 28-bit up/down counter is applied to the bus output latches. A sample command sends this data to the 10740A Coupler data lines.

### **4-19. OVERFLOW LATCH**

4-20. If the 28-bit up/down counter overflows, an overflow error signal is generated and is applied to the 10740A Coupler bus overflow line. The reset signal clears the overflow function. At zero counts (-160) the overflow is undefined and should be ignored.

Figure 4-2. 10762A Comparator Block Diagram

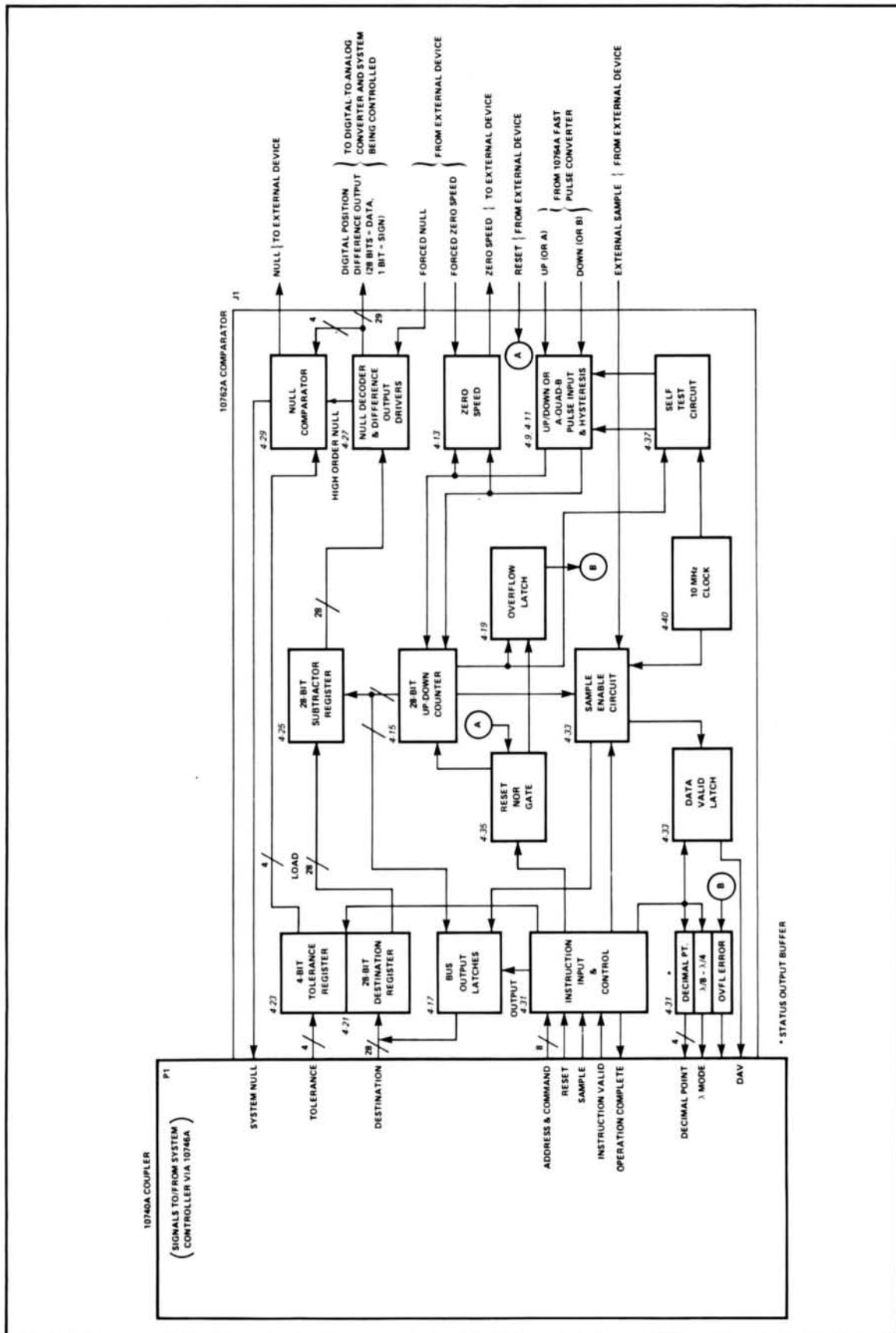

#### **4-21. 28-BIT DESTINATION REGISTER**

4-22. The 28-bit destination register (DR) accepts the binary data (from the 10740A Coupler bus) which specifies the desired position (destination) that the controlled device is intended to travel to. Output of the DR is the inversion or complement of the input. The DR loading function is actuated by a separate 10740A Coupler bus command: 3X. (Address X could be Y or Z or A or B or C.) Outputs of the DR are applied to the 28-bit subtractor. Loading the DR causes a forced null to be applied to the null decoder.

#### **4-23. 4-BIT TOLERANCE REGISTER**

4-24. The four-bit tolerance register receives the 4-bit tolerance from the system controller. The four tolerance bits are applied to the null comparator. The tolerance determines how close the controlled device will move to its destination. A null will be issued by the null comparator as soon as the tolerance is satisfied.

#### **4-25. 28-BIT SUBTRACTOR**

4-26. The 28-bit subtractor receives the data output of the destination register and the data output of the 28-bit up/down counter and provides the difference to the output drivers and null decoder. Note that the destination register output is the inversion (complement) of its input and the subtractor actually adds this complement to perform an effective subtraction in its output.

#### **4-27. NULL DECODER AND DIFFERENCE OUTPUT DRIVERS**

4-28. The null decoder monitors the output of the subtractor to detect when the device under control is at its destination (as indicated by the subtractor output reaching zero). The difference output drivers supply the digital position data which may be used to move the device under control. The difference output is in the form of 28 parallel data bit lines and one sign bit line. A forced null can be applied to the null decoder either from an external source or is automatically applied when the destination register receives a load command. The sample command from the controller releases the forced null (external sample will not release forced null).

#### **4-29. NULL COMPARATOR & NULL OUTPUTS**

4-30. The null comparator compares the lower four bits of the difference output to the four-bit tolerance in the tolerance register. When the difference is within tolerance, the null output sets the 10746A-to-controller system null line true (high) and sets the front connector null line true (low). Note that the system null line is wire-ANDed with all other comparator system null line outputs on the coupler backplane so the line will go true only after all comparators in the system have reached null.

#### **4-31. INSTRUCTION INPUT AND CONTROL**

4-32. The instruction input and control section accepts the correct instructions (addresses and commands) applied to the 10740A Coupler bus. This section decodes the instructions and passes them to other sections of the comparator. The OUTPUT signal enables the status bits for mode, overflow, and decimal point (tolerance bits) to be sent on the coupler bus.

#### **4-33. SAMPLE & DATA VALID CIRCUITS**

4-34. The sample function is used to transmit the contents of the 28-bit up/down counter onto the coupler data bus via the bus output latches. This can be enabled in any of three ways: an unaddressed sample signal from the 10740A Coupler bus, an addressed sample instruction, or an external sample input through the 10762A front connector. The sample function also releases the forced null applied to the null decoder when the destination register was loaded.

#### **4-35. RESET NOR GATE**

4-36. The reset NOR gate will accept the 10740A reset signal, or the command "0" from the coupler command lines, or the reset signal from the card front connector and set the internal 10762A reset lines true.

#### **4-37. SELF-TEST CIRCUIT**

4-38. The 28-bit up/down counter can be tested for proper operation by applying the correct command ("4" or "7") with the correct address on the 10740A Coupler bus. A "4" command causes the counter to count down to underflow; a "7" command causes the counter to count up to overflow. The 10 MHz clock is used for a time base.

4-39. The countup or countdown can be terminated prior to overflow or underflow by issuing a command, for example "1", or sample. This can be useful to preset the counter where an initial condition of greater than 160 counts is desired. Since a total countup takes about 27 seconds, the timing between the countup and sample commands must be determined empirically to obtain the desired counter contents.

#### **4-40. 10 MHz CLOCK**

4-41. The clock produces a crystal-controlled 10-MHz clock signal for the comparator sample enable and self test circuits. A clock test point is provided on the card.

#### **4-42. COMPARATOR/SYSTEM CONTROLLER RELATIONSHIP**

4-43. Typical operation of the comparator occurs in the following sequence. Instruction 0X at the command and address decoders (or either reset line set true) presets the up/down counter to 160. (The address portion of the instruction could be X or Y or Z or A or B or C depending on the address of the comparator.) Instruction 3X causes the comparator to load the data for the desired position and tolerance in the destination and tolerance registers. When the destination register is loaded, it starts the calculations of the difference between the up-down counter contents and the destination register contents. The calculation result (difference) is applied to the input of the output driver-null decoder section. Instruction 1X (or either sample line set true) causes 1) the null/difference output drivers to transfer the difference position bits out to the card front edge, and 2) causes the sample circuit to check if any counts are propagating through the up/down counter. When no counts are going through, the counter contents are applied to the bus output latches. Instruction 2X causes the bus output latches to apply their contents to the 10740A Coupler bus. Refer to Section IV of the 5501 Systems Manual for more information.

## **SECTION V MAINTENANCE**

### **5-1. INTRODUCTION**

5-2. This section contains maintenance and service information references for the 10762A.

### **5-3. MAINTENANCE AND TROUBLESHOOTING**

5-4. The 10762A does not operate separately from a Model 5501A Laser Transducer system and a 10740A Coupler. Procedures to isolate system troubles to this assembly are contained in the 5501A System Manual. Schematics, component location, and parts list are contained in this manual to aid in troubleshooting.

### **5-5. PREVENTIVE MAINTENANCE**

5-6. The preventive maintenance procedures given in the following paragraphs are provided to help prolong the useful life of the unit.

### **5-7. VISUAL INSPECTION**

5-8. Inspect the unit for indication of mechanical and electrical defects. Look for signs of overheating, corrosion, accumulations of dust, oil, loose electrical connections, or broken parts.

### **5-9. REPAIR AND CLEANING**

5-10. Repair any obvious defects; and if necessary clean the unit with a dry brush, suitable liquid solvent, or compressed clean dry air jet, or vacuum cleaner.

### **5-11. EXTENDER BOARD 10743A**

5-12. A 10762A can be operated out front of the 10740A Coupler using a Model 10743A printed-circuit extender board available from HP. When plugged in the 10740A Coupler, the 10743A feeds all the 10740A back-plane bus lines out to the front connector, which in turn accepts the 10762A.

### **5-13. TEST POINTS**

5-14. Test points are provided on the card for: ground, +5 volts, clock, up/down pulses and pulse mode.



## SECTION VI REPLACEABLE PARTS

### 6-1. INTRODUCTION

6-2. This section contains a manufacturer's code list (Table 6-1) and a listing of replaceable parts (Table 6-2). Refer to the 5501A Service Manual for parts ordering information and material abbreviations.

REFERENCE DESIGNATIONS					
<b>A</b> = assembly <b>AT</b> = attenuator, isolator, termination <b>B</b> = fan, motor <b>BT</b> = battery <b>C</b> = capacitor <b>CP</b> = coupler <b>CR</b> = diode, diode thyristor, varactor <b>DC</b> = directional coupler <b>DL</b> = delay line <b>DS</b> = annunciator, signaling device (audible or visual); lamp; LED	<b>E</b> = miscellaneous electrical part <b>F</b> = fuse <b>FL</b> = filter <b>H</b> = hardware <b>HY</b> = circulator <b>J</b> = electrical connector (stationary portion), jack <b>K</b> = relay <b>L</b> = coil, inductor <b>M</b> = meter <b>MP</b> = miscellaneous mechanical part	<b>P</b> = electrical connector (movable portion), plug <b>Q</b> = transistor, SCR, triode thyristor <b>R</b> = resistor <b>RT</b> = thermistor <b>S</b> = switch <b>T</b> = transformer <b>TB</b> = terminal board <b>TC</b> = thermocouple <b>TP</b> = test point <b>U</b> = integrated circuit, microcircuit	<b>V</b> = electron tube <b>VR</b> = voltage regulator, breakdown diode <b>W</b> = cable, transmission path, wire <b>X</b> = socket <b>Y</b> = crystal unit-piezo-electric <b>Z</b> = tuned cavity, tuned circuit		

*Table 6-1. Code List of Manufacturers*

Mfr. Number	Manufacturer Name	City	ZIP Code
55210	Gettig Engineering & Manufacturing Co., Inc.	Spring Mills, PA	16875
01121	Allen-Bradley Co.	Milwaukee, WI	53204
01295	Texas Instruments, Inc., Semiconductor Components Div.	Dallas, TX	75222
07263	Fairchild Semiconductor Division	Mountain View, CA	94042
11236	CTS of Berne, Inc.	Berne, IN	46711
11237	CTS of Keene, Inc.	Paso Robles, CA	93446
24546	Corning Glass Works (Bradford)	Bradford, PA	16701
18324	Signetics Corp.	Sunnyvale, CA	94086
24931	Specialty Connector Co., Inc.	Indianapolis, IN	46227
27014	National Semiconductor Corp.	Santa Clara, CA	95051
28480	Hewlett-Packard Company, Corporate Headquarters	Palo Alto, CA	94304
34355	Advanced Micro Devices, Inc.	Sunnyvale, CA	94086
56289	Sprague Electric Co.	North Adams, MA	01247
72136	Electro Motive Corp., Sub IEC	Willimantic, CT	06226

Table 6-2. Replaceable Parts

Reference Designation	HP Part Number	Qty	Description	Mfr Code	Mfr Part Number
A1	10762-00001	1	BOARD ASSEMBLY, COMPARATOR (SERIES 1728)	28480	10762-00001
C1	0160-2306	1	CAPACITOR-FXD 27PF +-5% 300VDC	28480	0160-2306
C2	0160-0572	1	CAPACITOR-FXD 2200PF +-20% 100VDC CER	28480	0160-0572
C3	0160-4084	1	CAPACITOR-FXD .1UF +-20% 50VDC CER	28480	0160-4084
C4	0160-3879	1	CAPACITOR-FXD .01UF +-20% 100VDC CER	28480	0160-3879
C5	0180-0210	9	CAPACITOR-FXD 3.3UF+-20% 15VDC TA	56289	150D335X0015A2
C6	0180-0022	1	CAPACITOR-FXD 3.9UF+-10% 35VDC TA	56289	150D395X0035B2
C7	0140-0151	1	CAPACITOR-FXD 820PF +-2% 300VDC MICA	72136	D415F821G0300HV1C
C8	0140-0234	1	CAPACITOR-FXD 500PF +-1% 300VDC MICA0+70	72136	D415F501F0300HV1C
C9	0160-0299	1	CAPACITOR-FXD 1800PF +-10% 200VDC POLYE	56289	292P18292
C10	0160-2055	11	CAPACITOR-FXD .01UF +-80-20% 100VDC CER	28480	0160-2055
C11	0180-0210		CAPACITOR-FXD 3.3UF+-20% 15VDC TA	56289	150D335X0015A2
C12	0160-2055		CAPACITOR-FXD .01UF +-80-20% 100VDC CER	28480	0160-2055
C13	0180-0210		CAPACITOR-FXD 3.3UF+-20% 15VDC TA	56289	150D335X0015A2
C14	0180-0210		CAPACITOR-FXD 3.3UF+-20% 15VDC TA	56289	150D335X0015A2
C15	0160-0945	1	CAPACITOR-FXD 910PF +-5% 100VDC MICA0+70	28480	0160-0945
C16	0160-2055		CAPACITOR-FXD .01UF +-80-20% 100VDC CER	28480	0160-2055
C17	0160-2055		CAPACITOR-FXD .01UF +-80-20% 100VDC CER	28480	0160-2055
C18	0160-2055		CAPACITOR-FXD .01UF +-80-20% 100VDC CER	28480	0160-2055
C19	0140-0225	1	CAPACITOR-FXD 300PF +-1% 300VDC MICA	72136	D415F301F0300HV1C
C20	0180-0210		CAPACITOR-FXD 3.3UF+-20% 15VDC TA	56289	150D335X0015A2
C21	0160-2055		CAPACITOR-FXD .01UF +-80-20% 100VDC CER	28480	0160-2055
C22	0180-0210		CAPACITOR-FXD 3.3UF+-20% 15VDC TA	56289	150D335X0015A2
C23	0180-0210		CAPACITOR-FXD 3.3UF+-20% 15VDC TA	56289	150D335X0015A2
C24	0160-2055		CAPACITOR-FXD .01UF +-80-20% 100VDC CER	28480	0160-2055
C25	0160-3456	1	CAPACITOR-FXD 1000PF +-10% 1KVDC CER	28480	0160-3456
C26	0180-0210		CAPACITOR-FXD 3.3UF+-20% 15VDC TA	56289	150D335X0015A2
C27	0160-2055		CAPACITOR-FXD .01UF +-80-20% 100VDC CER	28480	0160-2055
C28	0160-2055		CAPACITOR-FXD .01UF +-80-20% 100VDC CER	28480	0160-2055
C29	0160-2055		CAPACITOR-FXD .01UF +-80-20% 100VDC CER	28480	0160-2055
C30	0180-0210		CAPACITOR-FXD 3.3UF+-20% 15VDC TA	56289	150D335X0015A2
C31	0160-2055		CAPACITOR-FXD .01UF +-80-20% 100VDC CER	28480	0160-2055
CR1	1901-0040	4	DIODE-SWITCHING 30V 50MA 2N8 00-35	28480	1901-0040
CR2	1901-0040		DIODE-SWITCHING 30V 50MA 2N8 00-35	28480	1901-0040
CR3	1901-0040		DIODE-SWITCHING 30V 50MA 2N8 00-35	28480	1901-0040
CR4	1901-0040		DIODE-SWITCHING 30V 50MA 2N8 00-35	28480	1901-0040
DS1	1990-0487	3	LED-VISIBLE LUM=INT=1MCD IF=20MA=MAX	28480	1990-0487
DS2	1990-0487		LED-VISIBLE LUM=INT=1MCD IF=20MA=MAX	28480	1990-0487
DS3	1990-0487		LED-VISIBLE LUM=INT=1MCD IF=20MA=MAX	28480	1990-0487
J2	1250-0835	2	CONNECTOR-RF SMC M PC 50-OHM	24931	37JR104=2
J3	1250-0835		CONNECTOR-RF SMC M PC 50-OHM	24931	37JR104=2
Q1	1853-0015	1	TRANSISTOR PNP SI PD=200MH FT=500MHZ	28480	1853-0015
R1	0683-5115	3	RESISTOR 510 5% .25W FC TC=400/+600	01121	C85115
R2	0683-4725	36	RESISTOR 4.7K 5% .25W FC TC=400/+700	01121	C84725
R3	0683-4725		RESISTOR 4.7K 5% .25W FC TC=400/+700	01121	C84725
R4	0683-4725		RESISTOR 4.7K 5% .25W FC TC=400/+700	01121	C84725
R5	0683-4725		RESISTOR 4.7K 5% .25W FC TC=400/+700	01121	C84725
R6	0683-6815	2	RESISTOR 680 5% .25W FC TC=400/+600	01121	C86815
R7	0683-6815		RESISTOR 680 5% .25W FC TC=400/+600	01121	C86815
R8	0683-2015	3	RESISTOR 200 5% .25W FC TC=400/+600	01121	C82015
R9	0683-4705	2	RESISTOR 47 5% .25W FC TC=400/+500	01121	C84705
R10	0683-2015		RESISTOR 200 5% .25W FC TC=400/+600	01121	C82015
R11	0683-1015	1	RESISTOR 100 5% .25W FC TC=400/+500	01121	C81015
R12	0683-1025	6	RESISTOR 1K 5% .25W FC TC=400/+600	01121	C81025
R13	0683-1025		RESISTOR 1K 5% .25W FC TC=400/+600	01121	C81025
R14	0683-2015		RESISTOR 200 5% .25W FC TC=400/+600	01121	C82015
R15	0683-5115		RESISTOR 510 5% .25W FC TC=400/+600	01121	C85115
R16	0683-4725		RESISTOR 4.7K 5% .25W FC TC=400/+700	01121	C84725
R17	0683-1215	2	RESISTOR 120 5% .25W FC TC=400/+500	01121	C81215
R18	0683-1215		RESISTOR 120 5% .25W FC TC=400/+500	01121	C81215
R19	1810-0176	2	NETWORK-RES 5-PIN=81P .15-PIN=8PCG	11236	750
R20	0683-4725		RESISTOR 4.7K 5% .25W FC TC=400/+700	01121	C84725
R21	0683-4725		RESISTOR 4.7K 5% .25W FC TC=400/+700	01121	C84725
R22	0683-4725		RESISTOR 4.7K 5% .25W FC TC=400/+700	01121	C84725
R23	0683-4725		RESISTOR 4.7K 5% .25W FC TC=400/+700	01121	C84725
R24	0683-4725		RESISTOR 4.7K 5% .25W FC TC=400/+700	01121	C84725
R25	0683-5115		RESISTOR 510 5% .25W FC TC=400/+600	01121	C85115
R26	0683-1025		RESISTOR 1K 5% .25W FC TC=400/+600	01121	C81025
R27	0683-1025		RESISTOR 1K 5% .25W FC TC=400/+600	01121	C81025
R28	0683-4725		RESISTOR 4.7K 5% .25W FC TC=400/+700	01121	C84725
R29	0683-4725		RESISTOR 4.7K 5% .25W FC TC=400/+700	01121	C84725
R30	0683-4725		RESISTOR 4.7K 5% .25W FC TC=400/+700	01121	C84725

See introduction to this section for ordering information

Table 6-2. Replaceable Parts (cont'd)

Reference Designation	HP Part Number	Qty	Description	Mfr Code	Mfr Part Number
R31	0683-4725		RESISTOR 4.7K 5% .25W FC TC=400/+700	01121	CB4725
R32	0683-4725		RESISTOR 4.7K 5% .25W FC TC=400/+700	01121	CB4725
R33	0683-4725		RESISTOR 4.7K 5% .25W FC TC=400/+700	01121	CB4725
R34	0683-4725		RESISTOR 4.7K 5% .25W FC TC=400/+700	01121	CB4725
R35	0683-4725		RESISTOR 4.7K 5% .25W FC TC=400/+700	01121	CB4725
R36	0683-4725		RESISTOR 4.7K 5% .25W FC TC=400/+700	01121	CB4725
R37	0683-4725		RESISTOR 4.7K 5% .25W FC TC=400/+700	01121	CB4725
R38	0683-4725		RESISTOR 4.7K 5% .25W FC TC=400/+700	01121	CB4725
R39	0683-4725		RESISTOR 4.7K 5% .25W FC TC=400/+700	01121	CB4725
R40	0683-4725		RESISTOR 4.7K 5% .25W FC TC=400/+700	01121	CB4725
R41	0683-4725		RESISTOR 4.7K 5% .25W FC TC=400/+700	01121	CB4725
R42	0683-4725		RESISTOR 4.7K 5% .25W FC TC=400/+700	01121	CB4725
R43	0683-4725		RESISTOR 4.7K 5% .25W FC TC=400/+700	01121	CB4725
R44	0683-4725		RESISTOR 4.7K 5% .25W FC TC=400/+700	01121	CB4725
R45	0683-4725		RESISTOR 4.7K 5% .25W FC TC=400/+700	01121	CB4725
R46	0683-4725		RESISTOR 4.7K 5% .25W FC TC=400/+700	01121	CB4725
R47	0683-4725		RESISTOR 4.7K 5% .25W FC TC=400/+700	01121	CB4725
R48	0757-0952	1	RESISTOR 15K 2% .125W F TC=0/+100	24546	C4=1/8-T0-1502-G
R49	0757-0902	5	RESISTOR 120 2% .125W F TC=0/+100	24546	C4=1/8-T0-121-G
R50	0757-0902		RESISTOR 120 2% .125W F TC=0/+100	24546	C4=1/8-T0-121-G
R51	0683-4725		RESISTOR 4.7K 5% .25W FC TC=400/+700	01121	CB4725
R52	0757-0902		RESISTOR 120 2% .125W F TC=0/+100	24546	C4=1/8-T0-121-G
R53	0683-3315	2	RESISTOR 330 5% .25W FC TC=400/+600	01121	CB3315
R54	0683-3315		RESISTOR 330 5% .25W FC TC=400/+600	01121	CB3315
R55	0683-1025		RESISTOR 1K 5% .25W FC TC=400/+600	01121	CB1025
R56	0683-1025		RESISTOR 1K 5% .25W FC TC=400/+600	01121	CB1025
R57	0683-4725		RESISTOR 4.7K 5% .25W FC TC=400/+700	01121	CB4725
R58	1810-0176		NETWORK-RES 5-PIN-SIP .15-PIN-SPCG	11236	750
R59	0683-4725		RESISTOR 4.7K 5% .25W FC TC=400/+700	01121	CB4725
R60	0683-4705		RESISTOR 47 5% .25W FC TC=400/+500	01121	CB4705
R61	0757-0902		RESISTOR 120 2% .125W F TC=0/+100	24546	C4=1/8-T0-121-G
R62	0683-4725		RESISTOR 4.7K 5% .25W FC TC=400/+700	01121	CB4725
R63	0757-0902		RESISTOR 120 2% .125W F TC=0/+100	24546	C4=1/8-T0-121-G
R64	0683-4725		RESISTOR 4.7K 5% .25W FC TC=400/+700	01121	CB4725
R65	0683-4725		RESISTOR 4.7K 5% .25W FC TC=400/+700	01121	CB4725
R66	0683-3025	1	RESISTOR 3K 5% .25W FC TC=400/+700	01121	CB3025
R67	1810-0123	1	NETWORK-RES 8-PIN-SIP .125-PIN-SPCG	11236	750
S1	3101-1973	1	SWITCH-BL 7-1A-NB DIP-SLIDE-ASSY .1A	11237	11P-1028
TP1-	0360-1682	13	TERMINAL-STUD 8GL-TUR PRESS-MTG	28480	0360-1682
TP13	0360-1682		TERMINAL-STUD 8GL-TUR PRESS-MTG	28480	0360-1682
U16	1820-0806	1	IC GATE ECL OR-NOR DUAL 4-5-INP	18324	101098
U17	1820-1449	1	IC GATE TTL 8 OR QUAD 2-INP	01295	8N74832N
U18	1820-0693	3	IC FF TTL 8 D-TYPE POS-EDGE-TRIG	07263	74874PC
U19	1820-0721	1	IC RCVR TTL LINE RCVR DUAL 2-INP	27014	D88820AN
U21	1820-1323	1	IC GATE TTL 8 NAND 8-INP	01295	8N74830N
U27	1820-0704	1	IC MV TTL MONOSTBL RETRIG	01295	8N74122N
U28	1820-1307	1	IC SCHMITT-TRIG TTL 8 NAND QUAD 2-INP	01295	8N748132N
U31	1816-0636	7	IC 256-BIT ROM TTL	28480	1816-0636
U32	1816-0636		IC 256-BIT ROM TTL	28480	1816-0636
U33	1816-0636		IC 256-BIT ROM TTL	28480	1816-0636
U34	1816-0636		IC 256-BIT ROM TTL	28480	1816-0636
U35	1816-0636		IC 256-BIT ROM TTL	28480	1816-0636
U36	1816-0636		IC 256-BIT ROM TTL	28480	1816-0636
U37	1816-0636		IC 256-BIT ROM TTL	28480	1816-0636
U38	1820-1322	1	IC GATE TTL 8 NOR QUAD 2-INP	01295	8N74802N
U39	1820-1112	1	IC FF TTL 8 D-TYPE POS-EDGE-TRIG	01295	8N74LS74N
U41	1820-1441	7	IC ADDR TTL 8 BIN FULL ADDR 4-BIT	01295	8N74LS283N
U42	1820-1441		IC ADDR TTL 8 BIN FULL ADDR 4-BIT	01295	8N74LS283N
U43	1820-1441		IC ADDR TTL 8 BIN FULL ADDR 4-BIT	01295	8N74LS283N
U44	1820-1441		IC ADDR TTL 8 BIN FULL ADDR 4-BIT	01295	8N74LS283N
U45	1820-1441		IC ADDR TTL 8 BIN FULL ADDR 4-BIT	01295	8N74LS283N
U46	1820-1441		IC ADDR TTL 8 BIN FULL ADDR 4-BIT	01295	8N74LS283N
U47	1820-1441		IC ADDR TTL 8 BIN FULL ADDR 4-BIT	01295	8N74LS283N
U48	1820-1144	1	IC GATE TTL 8 NOR QUAD 2-INP	07263	9LS02PC
U49	1820-0693		IC FF TTL 8 D-TYPE POS-EDGE-TRIG	07263	74874PC
U51	1820-0233	7	IC CNTR TTL 8 BIN UP/DOWN SYNCHRO	27014	DW74193N
U52	1820-0233		IC CNTR TTL 8 BIN UP/DOWN SYNCHRO	27014	DW74193N
U53	1820-0233		IC CNTR TTL 8 BIN UP/DOWN SYNCHRO	27014	DW74193N
U54	1820-0233		IC CNTR TTL 8 BIN UP/DOWN SYNCHRO	27014	DW74193N
U55	1820-0233		IC CNTR TTL 8 BIN UP/DOWN SYNCHRO	27014	DW74193N
U56	1820-0233		IC CNTR TTL 8 BIN UP/DOWN SYNCHRO	27014	DW74193N
U57	1820-0233		IC CNTR TTL 8 BIN UP/DOWN SYNCHRO	27014	DW74193N
U58	1820-0904	1	IC COMPTN TTL L MAGTD 5-BIT	07263	93L24PC
U59	1820-1053	1	IC SCHMITT-TRIG TTL HEX 1-INP	01295	8N7414N
U61	1820-1195	8	IC FF TTL 8 D-TYPE POS-EDGE-TRIG COM	34335	AM74LS175A

See introduction to this section for ordering information

Table 6-2. Replaceable Parts (cont'd)

Reference Designation	HP Part Number	Qty	Description	Mfr Code	Mfr Part Number
U62	1820-1195		IC FF TTL L8 D-TYPE POS-EDGE-TRIG COM	34335	AM74L8175A
U63	1820-1195		IC FF TTL L8 D-TYPE POS-EDGE-TRIG COM	34335	AM74L8175A
U64	1820-1195		IC FF TTL L8 D-TYPE POS-EDGE-TRIG COM	34335	AM74L8175A
U65	1820-1195		IC FF TTL L8 D-TYPE POS-EDGE-TRIG COM	34335	AM74L8175A
U66	1820-1195		IC FF TTL L8 D-TYPE POS-EDGE-TRIG COM	34335	AM74L8175A
U67	1820-1195		IC FF TTL L8 D-TYPE POS-EDGE-TRIG COM	34335	AM74L8175A
U68	1820-1195		IC FF TTL L8 D-TYPE POS-EDGE-TRIG COM	34335	AM74L8175A
U69	1820-0621	1	IC BFR TTL NAND QUAD 2-INP	07263	7438PC
U71	1820-0574	7	IC FF TTL D-TYPE COM CLEAR QUAD	27014	DM8551N
U72	1820-0574		IC FF TTL D-TYPE COM CLEAR QUAD	27014	DM8551N
U73	1820-0574		IC FF TTL D-TYPE COM CLEAR QUAD	27014	DM8551N
U74	1820-0574		IC FF TTL D-TYPE COM CLEAR QUAD	27014	DM8551N
U75	1820-0574		IC FF TTL D-TYPE COM CLEAR QUAD	27014	DM8551N
U76	1820-0574		IC FF TTL D-TYPE COM CLEAR QUAD	27014	DM8551N
U77	1820-0574		IC FF TTL D-TYPE COM CLEAR QUAD	27014	DM8551N
U78	1820-1254	1	IC BFR TTL NON-INV HEX 1-INP	27014	DM8095N
U79	1816-0783	1	IC 256-BIT ROM TTL	28480	1816-0783
U110	1820-1200	1	IC INV TTL L8 HEX 1-INP	01295	SN74L805N
U210	1816-0784	1	IC SN748188 256-BIT ROM TTL	28480	1816-0784
U310	1820-1158	1	IC GATE TTL 8 AND-OR-INV DUAL 2-INP	01295	SN74851N
U410	1820-0693		IC FF TTL 8 D-TYPE POS-EDGE-TRIG	07263	74874PC
U510	1820-1197	1	IC GATE TTL L8 NAND QUAD 2-INP	01295	SN74L800N
U610	1820-1202	1	IC GATE TTL L8 NAND TPL 3-INP	07263	9L810PC
U710	1820-1418	1	IC DCOR TTL L8 BCD-TO-DEC 4-TO-10-LINE	01295	SN74L842N
Y1	0410-0423	1	CRYSTAL QUARTZ	28480	0410-0423
	1480-0116	2	EXTRACTOR PIN 1/16" DIA	7395G	GP24-063X250-12
	8159-0005	4	WIRE 22AWG N PVC 1x22 80C	55210	L-2007-1
	5040-1464	2	EXTRACTOR ICARD	28480	5040-1464
	5060-8339	1	KIT, CONNECTOR PC BOARD	28480	5060-8339

See introduction to this section for ordering information

## SECTION VII MANUAL CHANGES

### 7-1. INTRODUCTION

7-2. This section contains information necessary to adapt this manual to different series boards. Refer to the next section for an explanation of series numbers.

### 7-3. MANUAL UPDATING

7-4. If changes are made, newer instruments may have series numbers not listed in this manual. In this case, a manual change sheet with new information to describe newer instruments should accompany this manual. If the change sheet is missing ask for a copy from your nearest Hewlett-Packard Sales and Service office as listed at the end of this manual or the system manual.

### 7-5. MANUAL BACKDATING

7-6. This heading contains information necessary to allow this manual to completely describe older boards. Table 7-1 indicates the series number that designates a particular change. If your board has a series number listed, make the change listed so this manual will cover your board.

*Table 7-1. Manual Backdating*

If your board Has Series No.	Make Changes
1632A	1, 2
1728A	2

#### CHANGE 1

Page 2-8, paragraph 2-28 Address Switch "A,B,C,X,Y,Z" (S1):

Delete paragraphs 2-28 thru 2-31 and substitute the following:

#### **2-28. ADDRESS A,B,C,X,Y,Z JUMPER WIRES**

2-29. The 10762A operates in the Laser Transducer system through the 10740A Coupler backplane. A system controller, such as a calculator or computer, can be programmed to control one or more 10762A Comparators. Each 10762A in one system must have a separate "address" to receive instructions from the controller. Install one jumper (only) on each 10762A in line with the letter address selected (A, B, C, X, Y, or Z).

#### CHANGE 2

Page 8-5, Figure 8-2, Schematic Diagram:

At lower left of schematic, change R17 and R18 from 120 ohms to 51 ohms.

Page 6-2, Table 6-2, Replaceable Parts:

Change R17 and R18 from 0683-1215 to 0683-5105 RESISTOR 51 5% .25W FC TC = -400/+500, 01121, CB5105.

Page 2-7 and 8-3:

On the PC board, the gold-etched markings for J2 was UP/A. This was incorrect, J2 is used for the DWN/B connection. J3 was marked DWN/B, this was incorrect, J3 is used for the UP/A connection. Boards with series 1852A and above are marked correctly. Boards with series 1632A or 1728A were marked incorrectly.

**CHANGE 2 (Continued)**

Page 6-2, Table 6-1 Replaceable Parts:

Change R8 to 0683-2015 RESISTOR 200 OHMS 5% .25W FC TC=-400/+600.

Change U51-U57 to 1820-0233 IC CNTR TTL BIN UP/DOWN SYNCHRO.

Page 8-5, Figure 8-2 Schematic Diagram, sheet 2:

In 10 MHz CLOCK circuit, change R8 from "200" to "1K".

## SECTION VIII

# SCHEMATIC DIAGRAMS

### 8-1. INTRODUCTION

8-2. This section contains information for schematic diagrams, notes, reference designation system, identification markings on printed-circuit boards, schematic and component locators.

### 8-3. SCHEMATIC DIAGRAM NOTES

8-4. Figure 8-1 shows the symbols used on schematic diagrams. Component reference designations are assigned in vertical columns, left to right, according to physical layout on the board.

### 8-5. REFERENCE DESIGNATOR SYSTEM

8-6. Figure 8-1 shows the method of assigning reference designations. Assemblies such as printed-circuit boards are assigned in sequence, A1, A2, etc. As shown in Figure 8-1, subassemblies within assemblies are given a subordinate A number. For example, rectifier assembly A1 has the complete designator of A25A1. For individual components, the complete designator is determined by adding the assembly number and subassembly number if any. For example, CR1 on the rectifier assembly is designated A25A1CR1.

### 8-7. IDENTIFICATION MARKINGS ON PRINTED-CIRCUIT BOARDS

8-8. HP printed-circuit boards (see Figure 8-1) have four means of identification: an assembly part number, a series number, a revision letter, and a production code number.

8-9. The assembly part number has 10 digits (such as 10762-60001) and is the primary identification. All assemblies with the same part number are interchangeable. When a production change is made on an assembly that makes it incompatible with previous assemblies, a change in part number is required. The series number (such as 1248A) is used to document minor electrical changes. As changes are made, the series number is incremented. When replacement boards are ordered, you may receive a replacement with a different series number. If there is a difference between the series number marked on the board and the schematic in this manual, a minor electrical difference exists. If the number on the printed-circuit board is lower than that on the schematic, refer to Section VII for backdating information. If it is higher, refer to the loose-leaf manual change sheets for this manual. If the manual change sheets are missing, contact your local Hewlett-Packard Sales and Service Office. See the listing on the back cover of this manual.

8-10. Revision letters etched on the board (A, B, etc.) denote changes in printed circuit layout. For example, if a capacitor type is changed (electrical value may remain the same) and requires different spacing for its leads, the printed-circuit board layout is changed and the revision letter is incremented to the next letter. When a revision letter changes, the series number is also usually changed. The production code is the four-digit, seven-segment number used for production purposes.

Figure 8-1. Schematic Diagram Notes

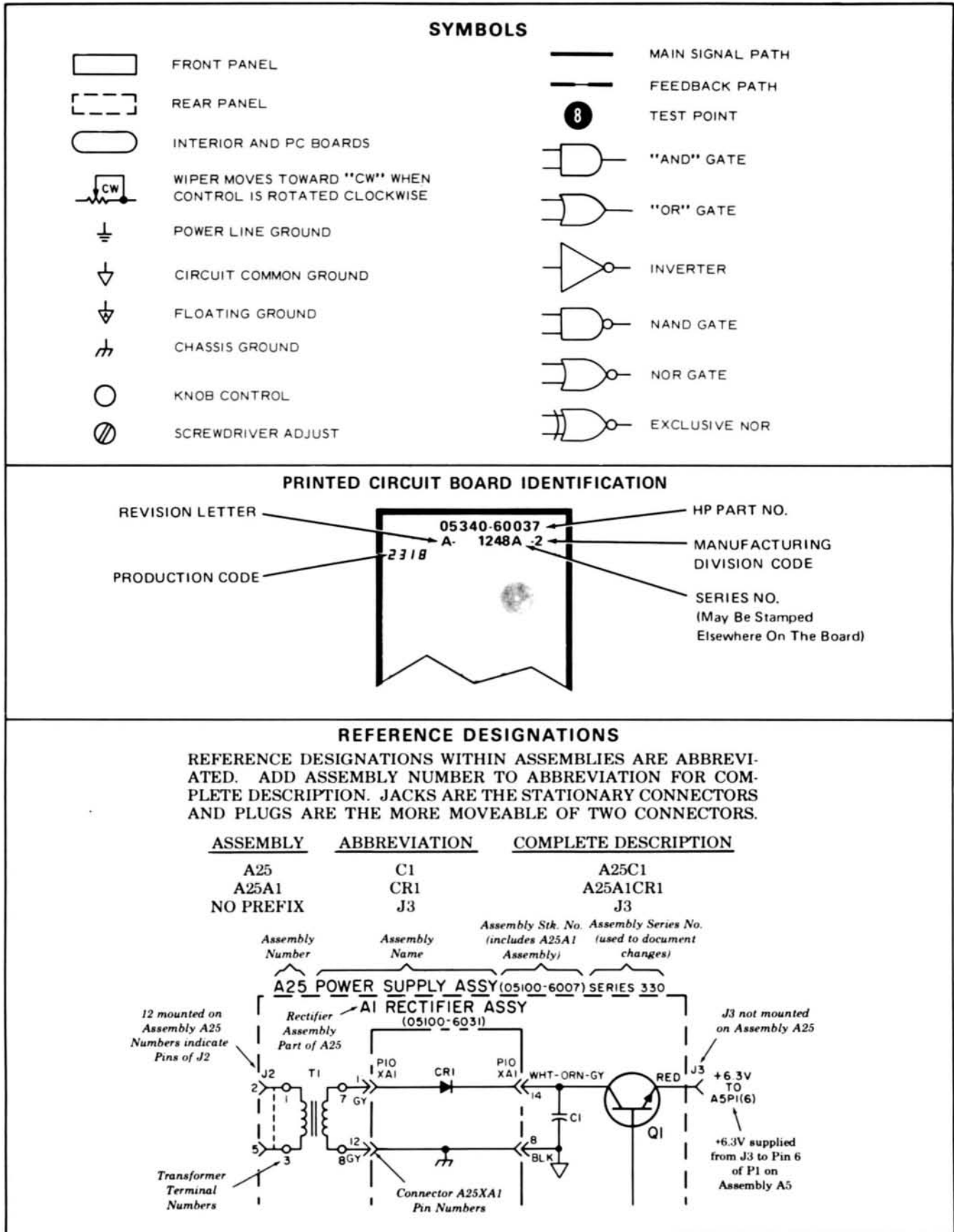



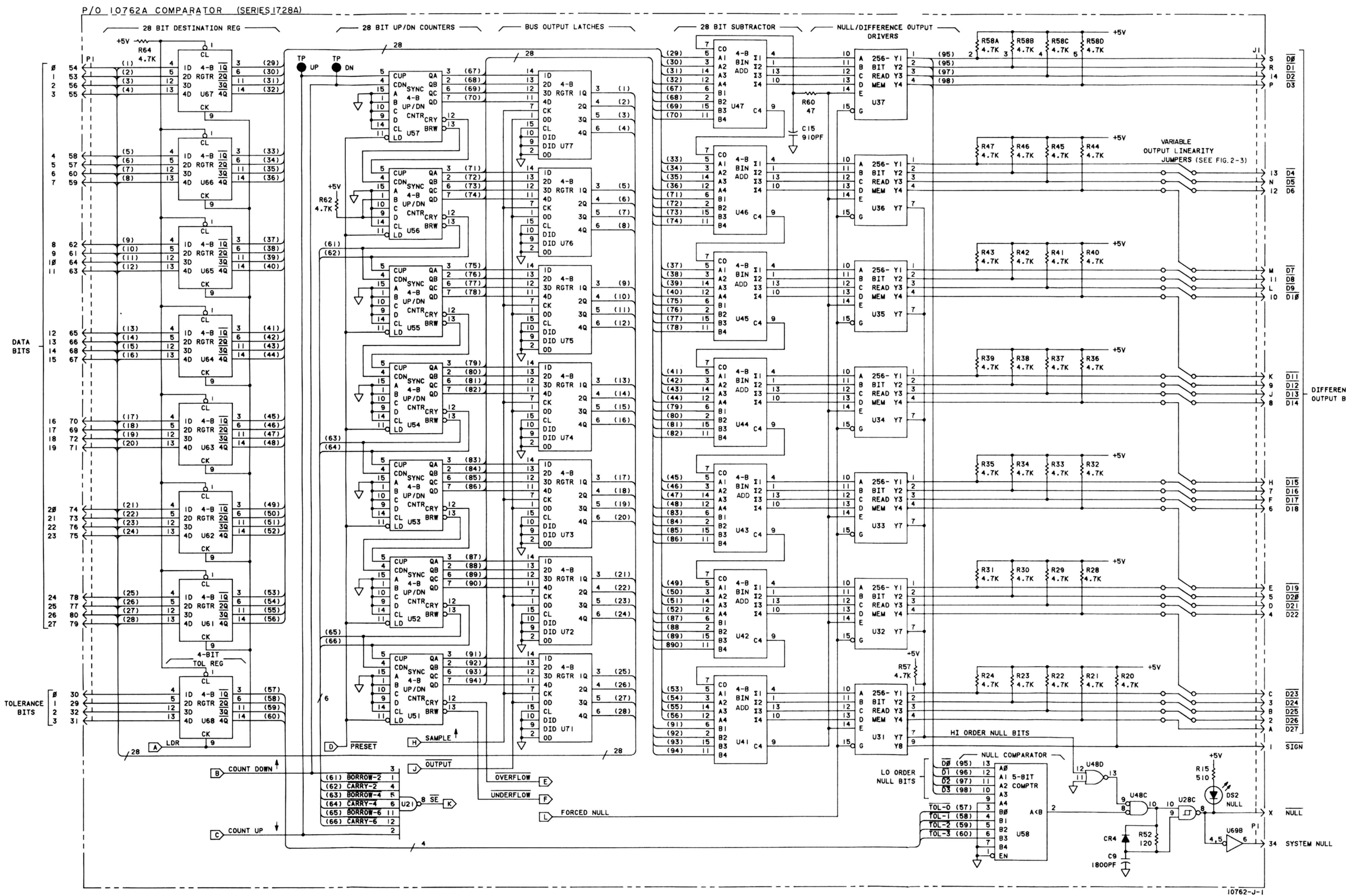
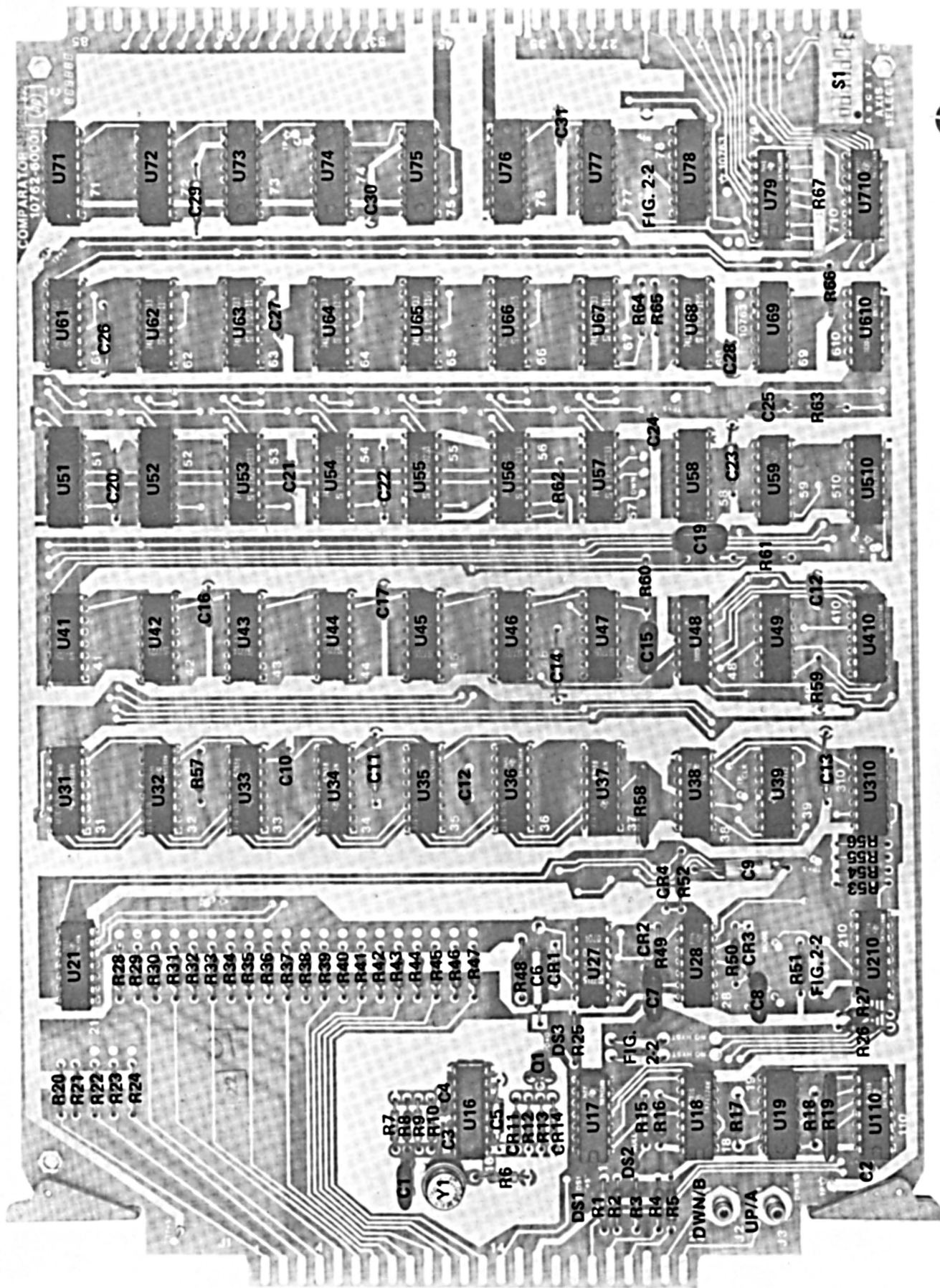

- NOTES:
1. REFERENCE DESIGNATIONS WITHIN THIS ASSEMBLY ARE ABBREVIATED. ADD ASSEMBLY NUMBER TO ABBREVIATION FOR COMPLETE DESCRIPTION.
  2. UNLESS OTHERWISE SPECIFIED: RESISTANCE IN OHMS. CAPACITANCE IN MICROFARADS.
  3. NUMBERS IN PARENS, ( ), ARE 'NAMES' USED TO IDENTIFY BUSSED SIGNALS. THESE NUMBERS APPLY ONLY ON THIS SCHEMATIC. LAST NUMBER USED-(98).

Figure 8-2. 10762A Comparator Schematic Diagram (Series 1728A) Sheet 1 of 2

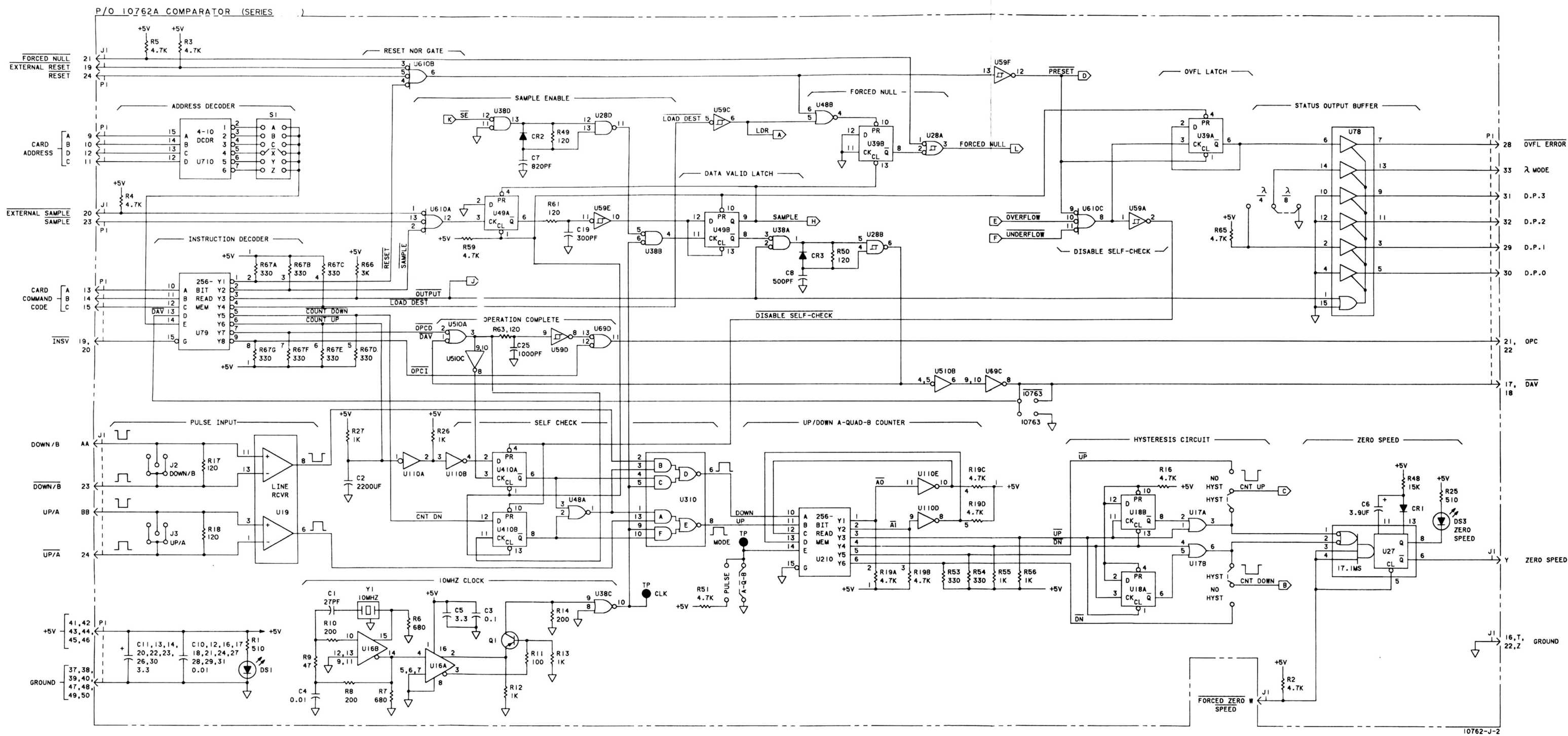

Figure 8-2. 10762A Comparator Schematic Diagram (Series 1728A) Sheet 2 of 2

